

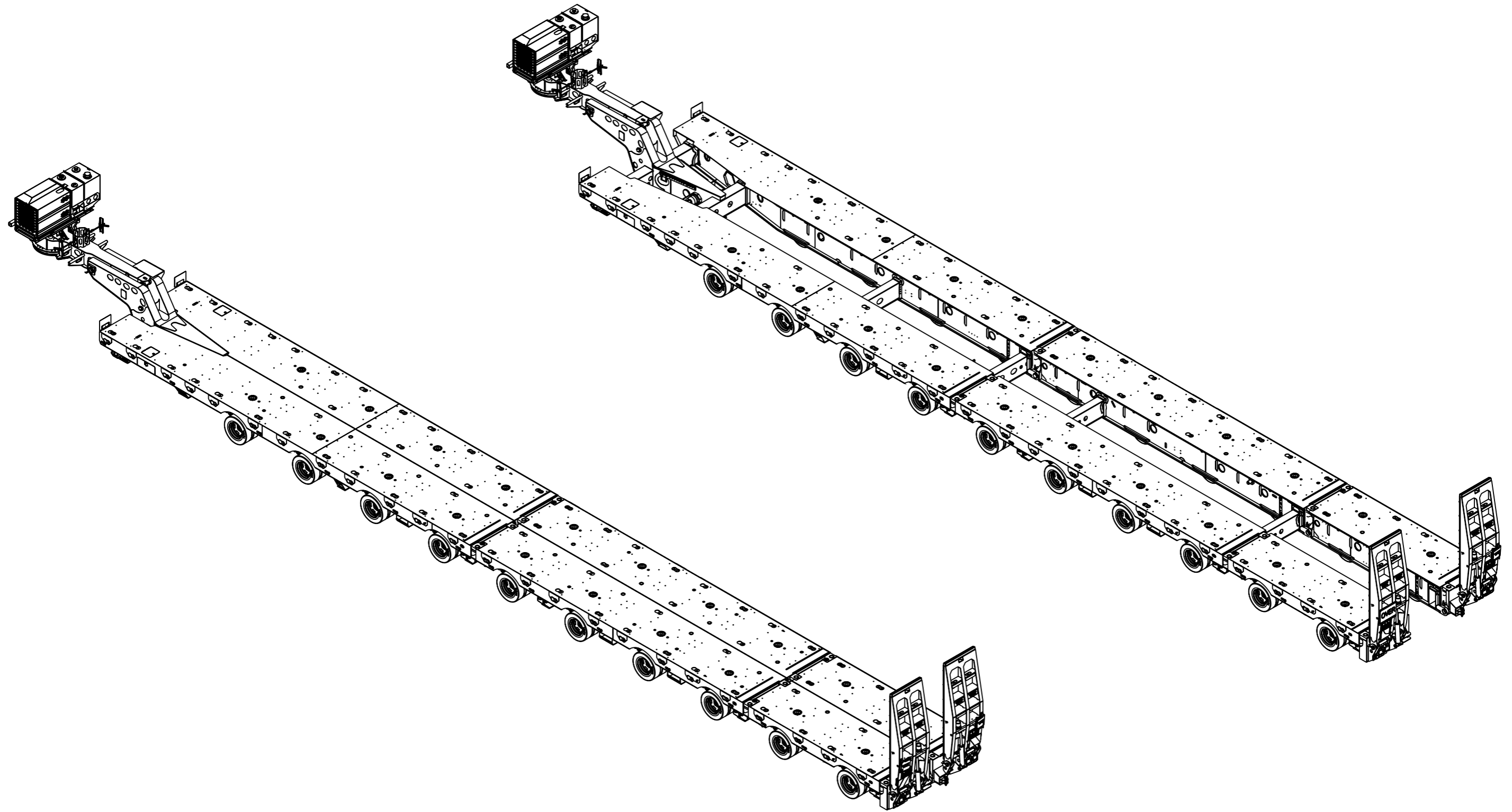

IF IN DOUBT PLEASE ASK



UNLESS OTHERWISE STATED

GENERAL TOLERANCES	0.00 = ± 0.05 0.0 = ± 0.2 0 = ± 0.5	 THIRD ANGLE PROJECTION
ANGLES	0 = ± 0.5°	



1.6
SURFACE FINISH (µm)

WELDING: ALL INFORMATION SHALL COMPLY WITH NZ/AS 1554:2000 PT 1 CATEGORY SP UNLESS OTHERWISE STATED AND SHALL BE WELDED TO A QUALIFIED PROCEDURE, BY A WELDER QUALIFIED FOR THE APPROPRIATE POSITION AND SUPERVISED BY A WELDING SUPERVISOR

THIS DRAWING IS © COPYRIGHT AND IS THE PROPERTY OF TIDD ROSS TODD LTD.
 IT IS FURNISHED TO YOU FOR CONFIDENTIAL INFORMATION PURPOSES ONLY AND IS NOT TO BE DISCLOSED TO ANYONE ELSE OR USED FOR MANUFACTURING PURPOSES WITHOUT THE EXPRESS WRITTEN PERMISSION OF TIDD ROSS TODD LTD.

REV	DATE	COMMENT	NAME



TIDD ROSS TODD LTD
 48 Maui Street, Hamilton,
 New Zealand
 Phone: +64 7 849 4839
 Email: trt@trt.co.nz
 Website: trt.co.nz
 ISO9001:2015

	NAME	DATE
DRAWN	JC	7/10/22
CHK'D	-	-
APPV'D	-	-

TITLE:		10 ROW PLATFORM	
SHEET 1 OF 3	DWG NO.	REVISION	
DO NOT SCALE DRAWINGS IN mm's	STATUS - M	SCALE:1:100	452-1004-W A

IF IN DOUBT PLEASE ASK

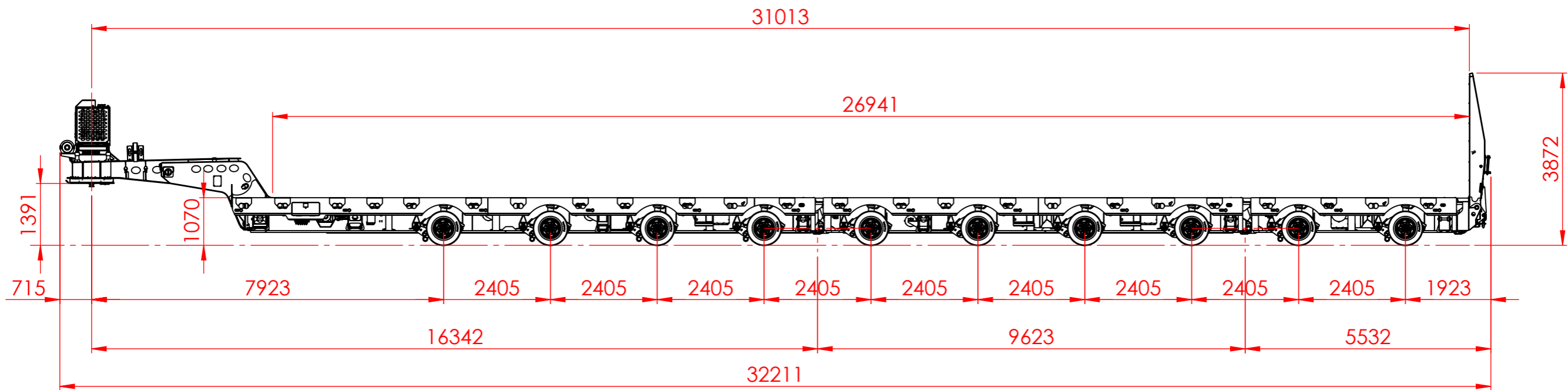
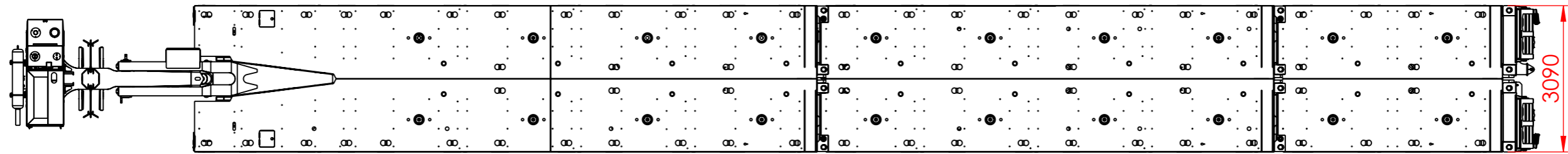

UNLESS OTHERWISE STATED

GENERAL TOLERANCES	0.00 = ± 0.05 0.0 = ± 0.2 0 = ± 0.5	THIRD ANGLE PROJECTION
ANGLES	0 = ± 0.5°	SURFACE FINISH (µm)

THIS DRAWING IS © COPYRIGHT AND IS THE PROPERTY OF TIDD ROSS TODD LTD. IT IS FURNISHED TO YOU FOR CONFIDENTIAL INFORMATION PURPOSES ONLY AND IS NOT TO BE DISCLOSED TO ANYONE ELSE OR USED FOR MANUFACTURING PURPOSES WITHOUT THE EXPRESS WRITTEN PERMISSION OF TIDD ROSS TODD LTD.

WELDING: ALL INFORMATION SHALL COMPLY WITH NZ/AS 1554:2000 PT 1 CATEGORY SP UNLESS OTHERWISE STATED AND SHALL BE WELDED TO A QUALIFIED PROCEDURE, BY A WELDER QUALIFIED FOR THE APPROPRIATE POSITION AND SUPERVISED BY A WELDING SUPERVISOR

REV	DATE	COMMENT	NAME



TIDD ROSS TODD LTD
48 Maui Street, Hamilton,
New Zealand
Phone: +64 7 849 4839
Email: trt@trt.co.nz
Website: trt.co.nz
ISO9001:2015

	NAME	DATE
DRAWN	JC	7/10/22
CHK'D	-	-
APPV'D	-	-

TITLE: 10 ROW PLATFORM		SHEET 2 OF 3	DWG NO. 452-1004-W	REVISION A
DO NOT SCALE DRAWINGS IN mm's	STATUS - M			

IF IN DOUBT PLEASE ASK

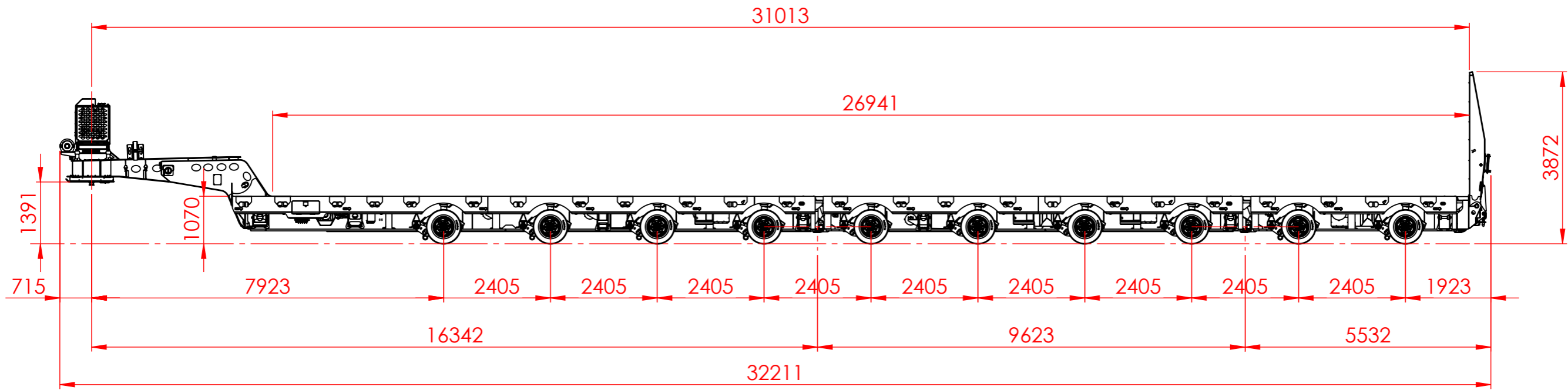
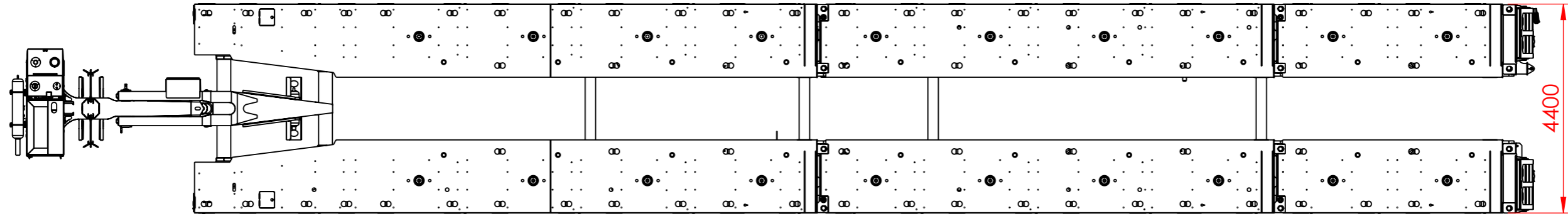

UNLESS OTHERWISE STATED

GENERAL TOLERANCES	0.00 = ± 0.05 0.0 = ± 0.2 0 = ± 0.5	THIRD ANGLE PROJECTION
ANGLES	0 = ± 0.5°	SURFACE FINISH (µm)

THIS DRAWING IS © COPYRIGHT AND IS THE PROPERTY OF TIDD ROSS TODD LTD.
IT IS FURNISHED TO YOU FOR CONFIDENTIAL INFORMATION PURPOSES ONLY AND IS NOT TO BE DISCLOSED TO ANYONE ELSE OR USED FOR MANUFACTURING PURPOSES WITHOUT THE EXPRESS WRITTEN PERMISSION OF TIDD ROSS TODD LTD.

WELDING: ALL INFORMATION SHALL COMPLY WITH NZ/AS 1554:2000 PT 1 CATEGORY SP UNLESS OTHERWISE STATED AND SHALL BE WELDED TO A QUALIFIED PROCEDURE, BY A WELDER QUALIFIED FOR THE APPROPRIATE POSITION AND SUPERVISED BY A WELDING SUPERVISOR

REV	DATE	COMMENT	NAME



TIDD ROSS TODD LTD
48 Maui Street, Hamilton,
New Zealand
Phone: +64 7 849 4839
Email: trt@trt.co.nz
Website: trt.co.nz
ISO9001:2015

	NAME	DATE
DRAWN	JC	7/10/22
CHK'D	-	-
APPV'D	-	-

TITLE: 10 ROW PLATFORM		SHEET 3 OF 3	DWG NO. 452-1004-W	REVISION A
DO NOT SCALE DRAWINGS IN mm's	STATUS - M			