

SPECIFICATIONS SUBJECT TO  
CHANGE WITHOUT NOTICE

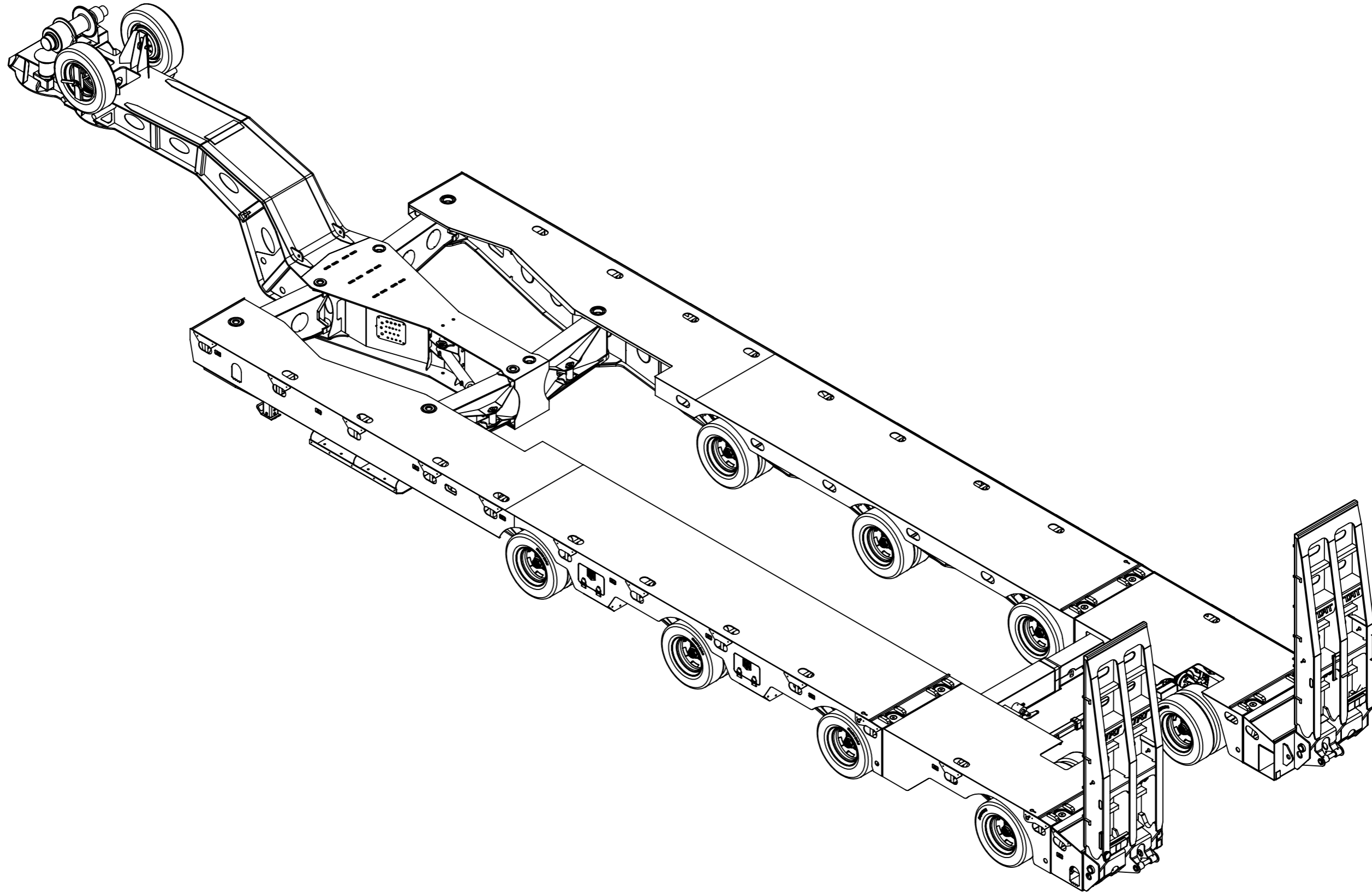
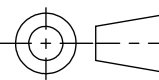

**TOLERANCE** : ± 0.5mm UNLESS OTHERWISE STATED  
**WIRE BUFF** ALL STEEL COMPONENTS PRIOR TO WELDING  
**WELDING**: ALL INFORMATION SHALL COMPLY WITH NZ/AS 1554:2000 PT 1 CATEGORY SP UNLESS OTHERWISE STATED AND SHALL BE WELDED TO A QUALIFIED PROCEDURE, BY A WELDER QUALIFIED FOR THE APPROPRIATE POSITION AND SUPERVISED BY A WELDING SUPERVISOR

THIS DRAWING IS © COPYRIGHT AND IS THE PROPERTY OF TIDD ROSS TODD LTD.  
 IT IS FURNISHED TO YOU FOR CONFIDENTIAL INFORMATION PURPOSES ONLY AND IS NOT TO BE DISCLOSED TO ANYONE ELSE OR USED FOR MANUFACTURING PURPOSES WITHOUT THE EXPRESS WRITTEN PERMISSION OF TIDD ROSS TODD LTD.

REV	DATE	COMMENT	NAME



**48 Maui Street**  
**Hamilton**  
**New Zealand**  
 Phone +64 7 849 4839  
 Fax +64 7 849 3628  
 Email : trt@trt.co.nz  
 ISO 9001

NAME	DATE	TITLE:	REVISION
DRAWN DT	24/04/2018	4 X 8 SWING WIDENING LOW LOADER	A
CHK'D -	-		
APPV'D -	-	SHEET 1 OF 3	DWG NO.
DO NOT SCALE DRAWINGS IN mm's	<b>STATUS - M</b>	SCALE:1:45	213-A11W

SPECIFICATIONS SUBJECT TO  
CHANGE WITHOUT NOTICE

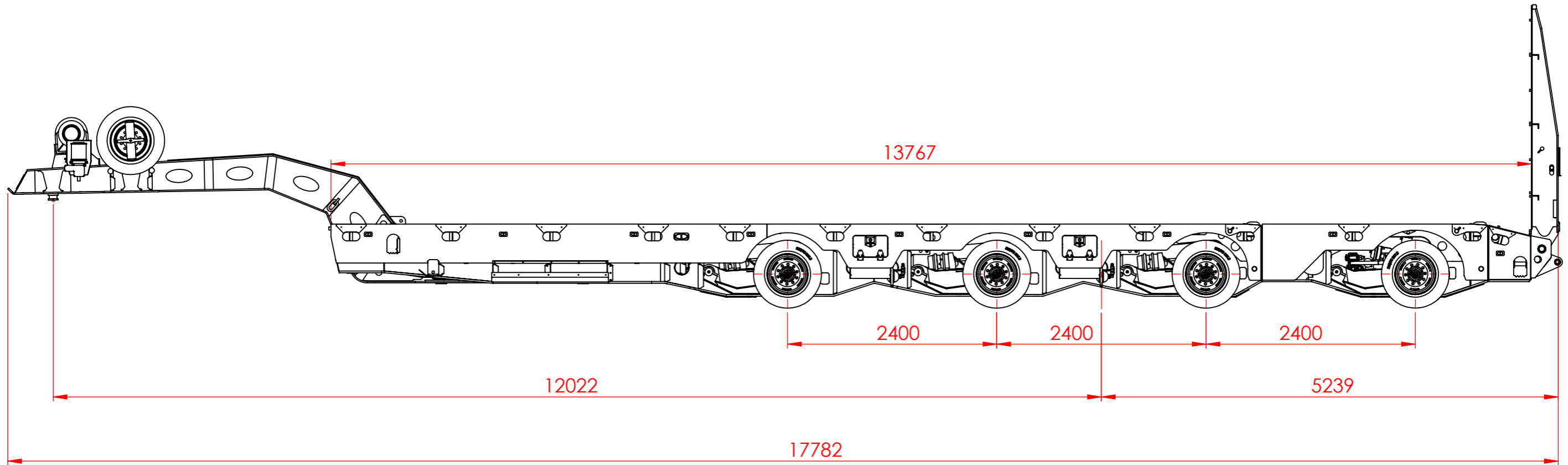
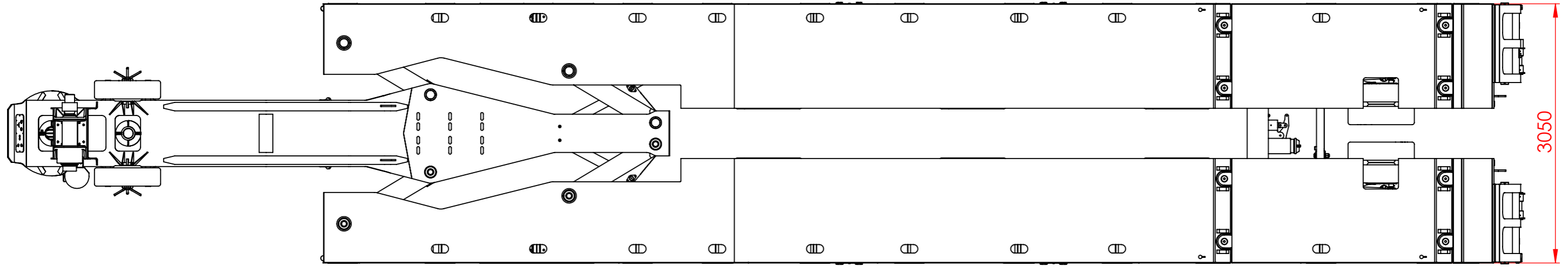

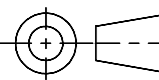
**TOLERANCE** : ± 0.5mm UNLESS OTHERWISE STATED  
**WELDING**: ALL INFORMATION SHALL COMPLY WITH NZ/AS 1554:2000 PT 1 CATEGORY SP UNLESS OTHERWISE STATED AND SHALL BE WELDED TO A QUALIFIED PROCEDURE, BY A WELDER QUALIFIED FOR THE APPROPRIATE POSITION AND SUPERVISED BY A WELDING SUPERVISOR  
**WIRE BUFF** ALL STEEL COMPONENTS PRIOR TO WELDING  
 THIS DRAWING IS © COPYRIGHT AND IS THE PROPERTY OF TIDD ROSS TODD LTD. IT IS FURNISHED TO YOU FOR CONFIDENTIAL INFORMATION PURPOSES ONLY AND IS NOT TO BE DISCLOSED TO ANYONE ELSE OR USED FOR MANUFACTURING PURPOSES WITHOUT THE EXPRESS WRITTEN PERMISSION OF TIDD ROSS TODD LTD.

REV	DATE	COMMENT	NAME



**48 Maui Street**  
**Hamilton**  
**New Zealand**  
 Phone +64 7 849 4839  
 Fax +64 7 849 3628  
 Email : trt@trt.co.nz  
 ISO 9001

	NAME	DATE
DRAWN	DT	24/04/2018
CHK'D	-	-
APPV'D	-	-

TITLE:		REVISION	
4 X 8 SWING WIDENING LOW LOADER		A	
SHEET 2 OF 3	DWG NO.	213-A11W	
DO NOT SCALE DRAWINGS IN mm's	<b>STATUS - M</b>	SCALE:1:48	

SPECIFICATIONS SUBJECT TO  
CHANGE WITHOUT NOTICE

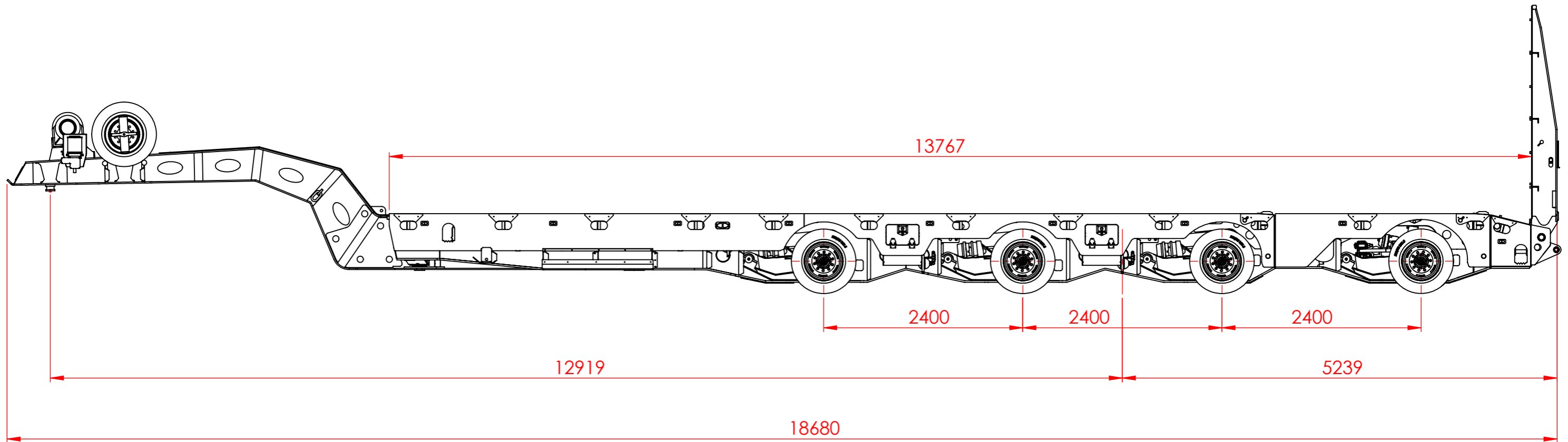
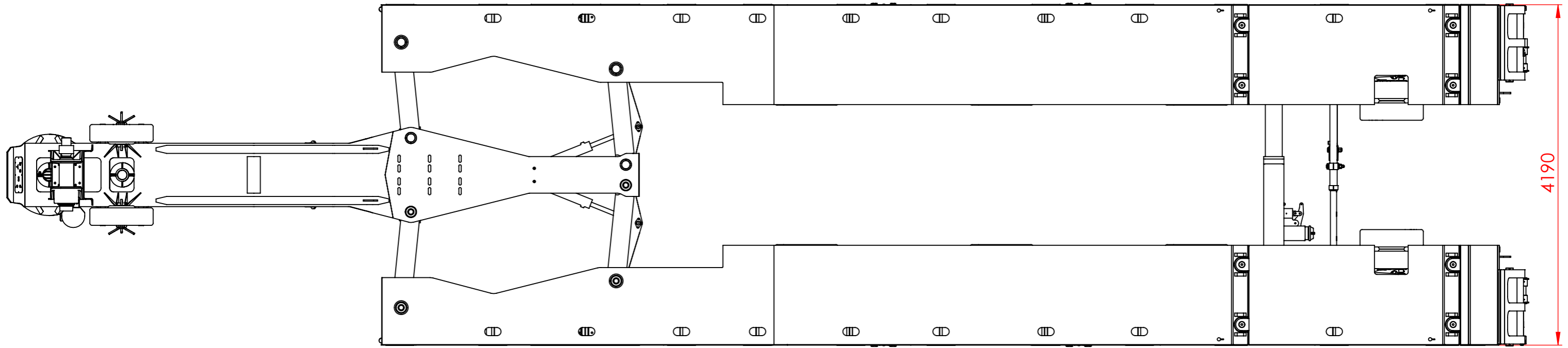

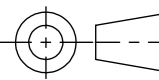
**TOLERANCE** : ± 0.5mm UNLESS OTHERWISE STATED  
**WIRE BUFF ALL STEEL COMPONENTS PRIOR TO WELDING**

THIS DRAWING IS © COPYRIGHT AND IS THE PROPERTY OF TIDD ROSS TODD LTD. IT IS FURNISHED TO YOU FOR CONFIDENTIAL INFORMATION PURPOSES ONLY AND IS NOT TO BE DISCLOSED TO ANYONE ELSE OR USED FOR MANUFACTURING PURPOSES WITHOUT THE EXPRESS WRITTEN PERMISSION OF TIDD ROSS TODD LTD.

**WELDING:** ALL INFORMATION SHALL COMPLY WITH NZ/AS 1554:2000 PT 1 CATEGORY SP UNLESS OTHERWISE STATED AND SHALL BE WELDED TO A QUALIFIED PROCEDURE, BY A WELDER QUALIFIED FOR THE APPROPRIATE POSITION AND SUPERVISED BY A WELDING SUPERVISOR

REV	DATE	COMMENT	NAME



48 Maui Street  
 Hamilton  
 New Zealand  
 Phone +64 7 849 4839  
 Fax +64 7 849 3628  
 Email : trt@trt.co.nz  
 ISO 9001

NAME	DATE	TITLE:	REVISION
DRAWN DT	24/04/2018	4 X 8 SWING WIDENING LOW LOADER	A
CHK'D -	-		
APPV'D -	-	SHEET 3 OF 3	DWG NO.
DO NOT SCALE DRAWINGS IN mm's	<b>STATUS - M</b>	SCALE:1:48	213-A11W