

SPECIFICATIONS SUBJECT TO  
CHANGE WITHOUT NOTICE

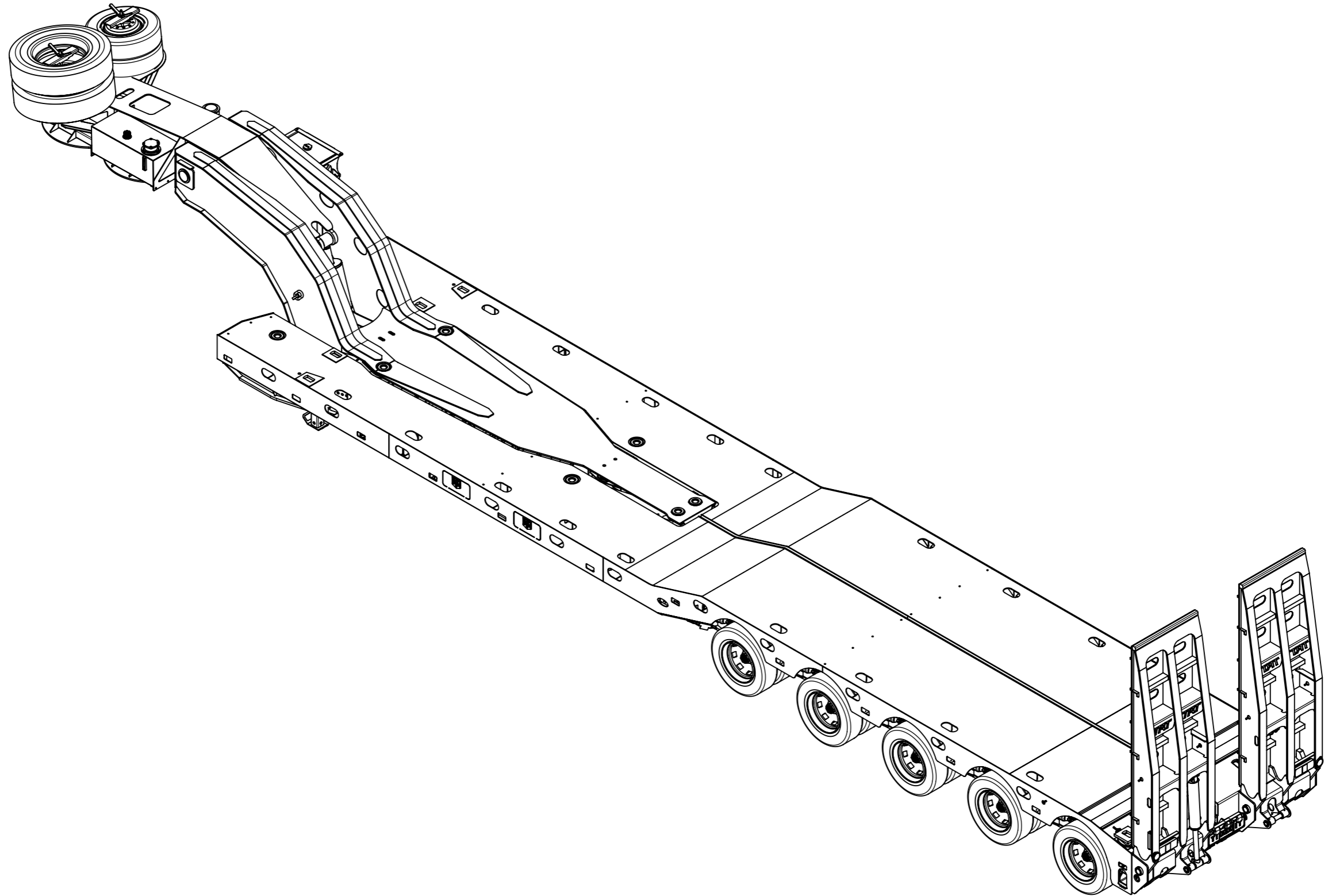

THIS DRAWING IS © COPYRIGHT AND IS THE PROPERTY OF TIDD ROSS TODD LTD. IT IS FURNISHED TO YOU FOR CONFIDENTIAL INFORMATION PURPOSES ONLY AND IS NOT TO BE DISCLOSED TO ANYONE ELSE OR USED FOR MANUFACTURING PURPOSES WITHOUT THE EXPRESS WRITTEN PERMISSION OF TIDD ROSS TODD LTD.

REV	DATE	COMMENT	NAME



48 Maui Street  
Hamilton  
New Zealand  
Phone +64 7 849 4839  
Fax +64 7 849 3628  
Email : trt@trt.co.nz  
ISO 9001

	NAME	DATE
DRAWN	DM	24/04/2018
CHK'D	-	-
APPV'D	-	-

TITLE: 5x8 SWING WING WIDENING LOWLOADER WITH DROP WELL		SHEET 1 OF 3		DWG NO. 174-A1 W		REVISION A	
DO NOT SCALE DRAWINGS IN mm's		<b>STATUS - M</b>		SCALE:1:45			

**TOLERANCE** : ± 0.5mm UNLESS OTHERWISE STATED  
**WELDING**: ALL INFORMATION SHALL COMPLY WITH NZ/AS 1554:2000 PT 1 CATEGORY SP UNLESS OTHERWISE STATED AND SHALL BE WELDED TO A QUALIFIED PROCEDURE, BY A WELDER QUALIFIED FOR THE APPROPRIATE POSITION AND SUPERVISED BY A WELDING SUPERVISOR

WIRE BUFF ALL STEEL COMPONENTS PRIOR TO WELDING

SPECIFICATIONS SUBJECT TO  
CHANGE WITHOUT NOTICE

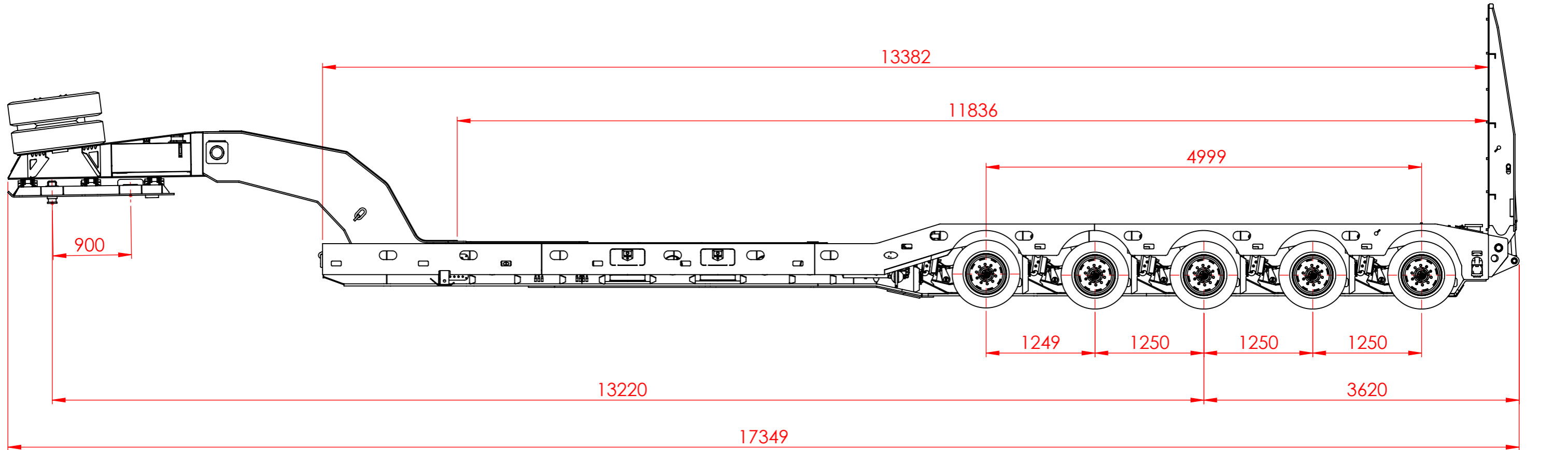
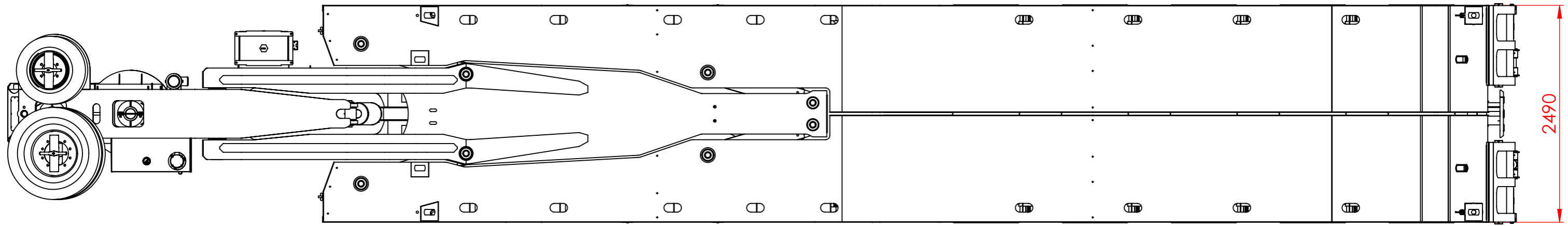

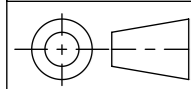
 **TOLERANCE** : ± 0.5mm UNLESS OTHERWISE STATED  
**WIRE BUFF** ALL STEEL COMPONENTS PRIOR TO WELDING

**WELDING**: ALL INFORMATION SHALL COMPLY WITH NZ/AS 1554:2000 PT 1 CATEGORY SP UNLESS OTHERWISE STATED AND SHALL BE WELDED TO A QUALIFIED PROCEDURE, BY A WELDER QUALIFIED FOR THE APPROPRIATE POSITION AND SUPERVISED BY A WELDING SUPERVISOR

THIS DRAWING IS © COPYRIGHT AND IS THE PROPERTY OF TIDD ROSS TODD LTD. IT IS FURNISHED TO YOU FOR CONFIDENTIAL INFORMATION PURPOSES ONLY AND IS NOT TO BE DISCLOSED TO ANYONE ELSE OR USED FOR MANUFACTURING PURPOSES WITHOUT THE EXPRESS WRITTEN PERMISSION OF TIDD ROSS TODD LTD.

REV	DATE	COMMENT	NAME



**48 Maui Street**  
**Hamilton**  
**New Zealand**  
Phone +64 7 849 4839  
Fax +64 7 849 3628  
Email : trt@trt.co.nz  
ISO 9001

	NAME	DATE
DRAWN	DM	24/04/2018
CHK'D	-	-
APPV'D	-	-

TITLE:		REVISION	
5x8 SWING WING WIDENING LOWLOADER WITH DROP WELL		A	
SHEET 2 OF 3	DWG NO.	174-A1 W	
DO NOT SCALE DRAWINGS IN mm's	<b>STATUS - M</b>	SCALE:1:45	

SPECIFICATIONS SUBJECT TO  
CHANGE WITHOUT NOTICE

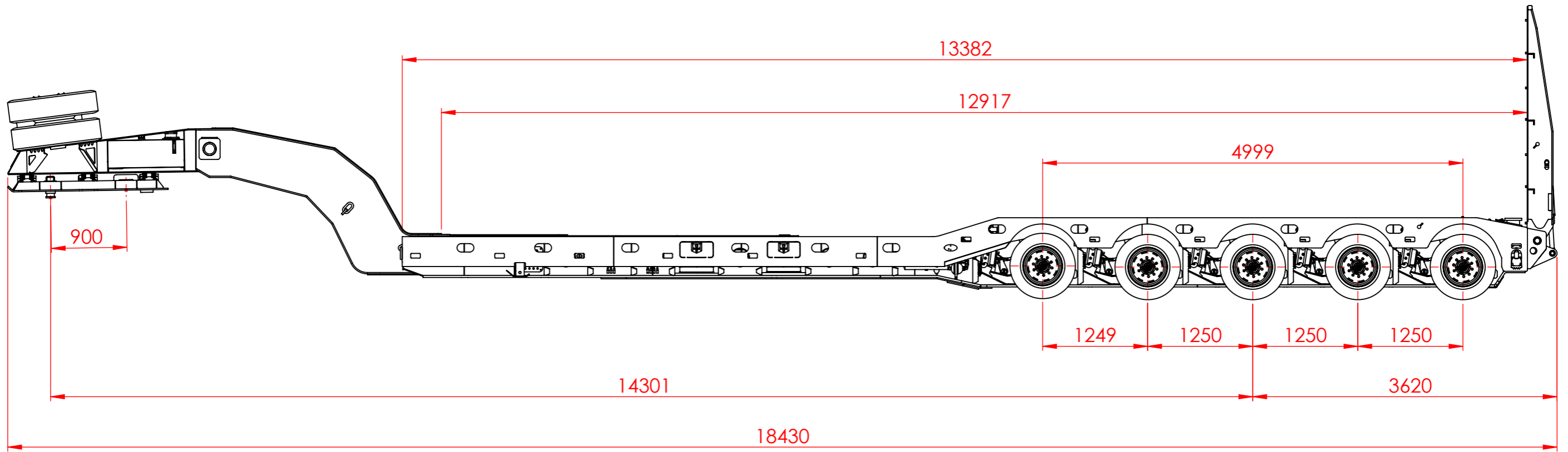
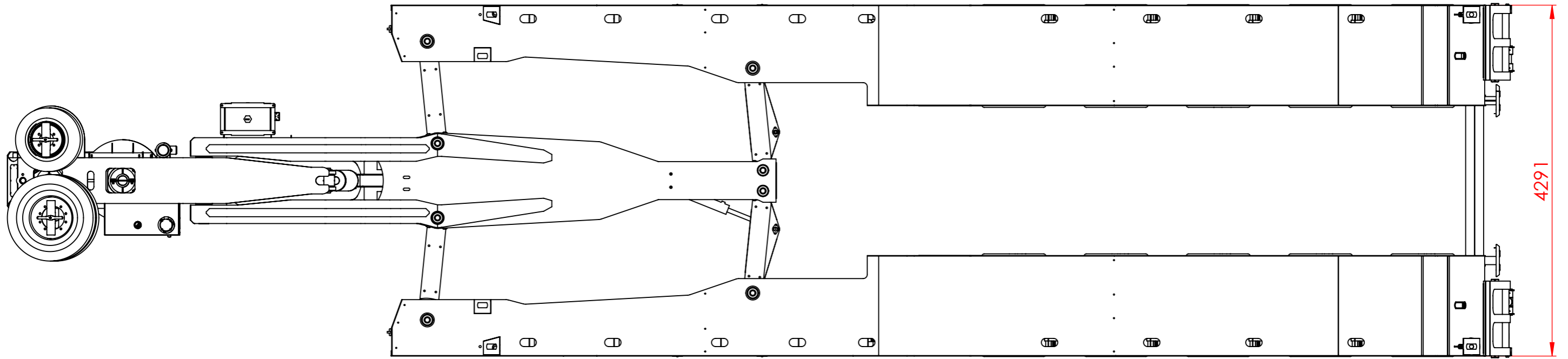

**TOLERANCE** : ± 0.5mm UNLESS OTHERWISE STATED  
WIRE BUFF ALL STEEL COMPONENTS PRIOR TO WELDING

**WELDING**: ALL INFORMATION SHALL COMPLY WITH NZ/AS 1554:2000 PT 1 CATEGORY SP UNLESS OTHERWISE STATED AND SHALL BE WELDED TO A QUALIFIED PROCEDURE, BY A WELDER QUALIFIED FOR THE APPROPRIATE POSITION AND SUPERVISED BY A WELDING SUPERVISOR

THIS DRAWING IS © COPYRIGHT AND IS THE PROPERTY OF TIDD ROSS TODD LTD.  
IT IS FURNISHED TO YOU FOR CONFIDENTIAL INFORMATION PURPOSES ONLY AND IS NOT TO BE DISCLOSED TO ANYONE ELSE OR USED FOR MANUFACTURING PURPOSES WITHOUT THE EXPRESS WRITTEN PERMISSION OF TIDD ROSS TODD LTD.

REV	DATE	COMMENT	NAME



**48 Maui Street**  
**Hamilton**  
**New Zealand**  
Phone +64 7 849 4839  
Fax +64 7 849 3628  
Email : trt@trt.co.nz  
ISO 9001

	NAME	DATE
DRAWN	DM	24/04/2018
CHK'D	-	-
APPV'D	-	-

TITLE:		REVISION	
5x8 SWING WING WIDENING LOWLOADER WITH DROP WELL		A	
SHEET 3 OF 3	DWG NO.	174-A1 W	
DO NOT SCALE DRAWINGS IN mm's	<b>STATUS - M</b>	SCALE:1:50	